

Features

- 4:1 Wide Input Range
- Operating Temperature Range: -40~105°
- Approved to cURus, UKCA, C
- Safety Standards to IEC/UL/EN62368-1, EN45545-2
- Efficiency up to 90%
- EMC Class A & B
- Single 100W Output Models
- Available with optional heatsink (HS)



Ideal Power's 43QAE100-xSyW 100W Series Pin Connection DC/DC Converters are certified to cURus, UKCA, CE, RoHS, REACH & IEC/UL/EN 62368-1, EN45545-2 Standards and comply with Efficiency Regulations. These are primarily used in ITE, Video & Audio, Railway Industries and customised solutions are available upon request.

Part Number Structure

43QAE100-	48	S	05	W -	P	HS
Series Name	Output Power (VDC)	Output Quantity	Output Voltage (VDC)	Input Range	Ctrl and Pin Options	Assembly Options
	24: 8.5~36 48: 16.5~75 110: 40~160	S: Single	3P3: 3.3 05: 5 12: 12 15: 15 24: 24 30: 30 48: 48	4:1	<input type="checkbox"/> : Negative logic <input checked="" type="checkbox"/> : Positive logic	<input type="checkbox"/> : None Heat-sink type: HS: 7G-0029B-F;H=0.24" HS1: 7G-0030B-F;H=0.5" HS2: 7G-0031B-F;H=0.24" HS3: 7G-0032B-F;H=0.5" HS4: 7GA0124P01-F;H=0.65" HS5: 7GA0125P01-F;H=1" Through hole type TH: No thread*

* The module can't equip Heat-sink with TH option

Models

Model Number	Input Range	Output Voltage	Output Current @Full Load mA	Input Current @No Load mA	Efficiency %	Maximum Capacitor Load μF
43QAE100-24S3P3W	8.5~36	3.3	25	25	88	75000
43QAE100-24S05W	8.5~36	5	18	25	89	36000
43QAE100-24S12W	8.5~36	12	7.5	25	89	6250
43QAE100-24S15W	8.5~36	15	6	25	89	4000
43QAE100-24S24W	8.5~36	24	3.7	25	89	1540
43QAE100-24S30W	8.5~36	30	3	25	89	1000
43QAE100-24S48W	8.5~36	48	1.8	25	88	380
43QAE100-48S3P3W	16.5~75	3.3	25	15	88	75000
43QAE100-48S05W	16.5~75	5	18	15	89	36000
43QAE100-48S12W	16.5~75	12	7.5	15	89	6250
43QAE100-48S15W	16.5~75	15	6	15	90	4000
43QAE100-48S24W	16.5~75	24	3.7	15	90	1540
43QAE100-48S30W	16.5~75	30	3	15	90	1000
43QAE100-48S48W	16.5~75	48	1.8	15	90	380
43QAE100-110S3P3W	40~160	3.3	23	8	88	70000
43QAE100-110S05W	40~160	5	17	8	89	34000
43QAE100-110S12W	40~160	12	7	8	89	5830
43QAE100-110S15W	40~160	15	5.5	8	89	3670
43QAE100-110S24W	40~160	24	3.5	8	89	1460
43QAE100-110S30W	40~160	30	2.8	8	89	930
43QAE100-110S48W	40~160	48	1.8	8	89	380

Input Specifications

Parameter	Conditions	Min	Typ	Max	Unit	
Operating input voltage range	24Vin(nom)	8.5	24	36	VDC	
	48Vin(nom)	16.5	48	75		
	110Vin(nom)	40	110	160		
Start up voltage	24Vin(nom)	--	--	9	VDC	
	48Vin(nom)	--	--	18		
	110Vin(nom)	--	--	43		
Shutdown voltage	24Vin(nom)	7.3	7.7	8.1	VDC	
	48Vin(nom)	15.5	15.9	16.3		
	110Vin(nom)	33.0	34.5	36.0		
Start up time	Constant resistive load	Power up	--	75	100	ms
		Remote ON/OFF	--	75	100	
Input surge voltage	1 second, max.	24Vin(nom)	--	--	50	VDC
		48Vin(nom)	--	--	100	
		110Vin(nom)	--	--	185	
Input filter (1)		Pi type				
Remote ON/OFF	Referred to –Vin pin	Negative logic	DC-DC ON	Short or 0 ~ 1.2VDC		
		(Standard)	DC-DC OFF	Open or 3 ~ 12VDC		
		Positive logic	DC-DC ON	Open or 3 ~ 12VDC		
		(Option)	DC-DC OFF	Short or 0 ~ 1.2VDC		
		Input current of Ctrl pin	--	-0.5	--	1
Remote off input current	--	--	3	--	mA	

Output Specifications

Parameter	Conditions	Min	Typ	Max	Unit	
Voltage accuracy		-1.0	--	+1.0	%	
Line regulation	Low Line to High Line at Full Load	-0.1	--	+0.1	%	
Load regulation	No Load to Full Load	3.3 & 5Vout	-0.2	--	+0.2	%
		Others	-0.1	--	+0.1	%
Voltage adjustability	Maximum output deviation is inclusive of remote sense	-20	--	+10	%	
Remote sense	% of Vout(nom). If remote sense is not being used, SENSE pins should connect to the output pins with the same polarity.		--	10	%	
Ripple and noise	Measured by 20MHz bandwidth					
	With a 22µF/25V X7R MLCC	3.3Vout, 5Vout	--	75	--	mVp-p
	With a 22µF/25V X7R MLCC	12Vout, 15Vout	--	100	--	
	With a 4.7µF/50V X7R MLCC	24Vout, 30Vout	--	200	--	
With a 2.2µF/100V X7R MLCC	48Vout	--	300	--		
Temperature coefficient		-0.02	--	+0.02	%/°C	
Transient response recovery time	25% load step change	--	250	--	µs	
Over voltage protection	% of Vout(nom); Hiccup mode	115	--	130	%	
Overload protection	% of Iout rated; Hiccup mode	110	--	140	%	
Short circuit protection		Continuous, automatic recovery				

General Specifications

Parameter	Conditions	Min	Typ	Max	Unit	
Isolation voltage	1 minute	110Vin(nom)	Input to Output	3000	--	VDC
	(Reinforced insulation)		Input (Output) to Base-Plate	1500	--	
	1 minute	Others	Input to Output	2250	--	VAC
	(Basic insulation)		Input (Output) to Base-Plate	2250	--	
Isolation resistance	500VDC	1	--	--	GΩ	
Isolation capacitance		--	--	1500	pF	
Switching frequency		270	300	330	kHz	
Safety approvals	IEC/ EN/ UL62368-1				UL:E193009 CB:UL(Demko)	
Standard approvals	EN50155 EN45545-2					
Case material		Aluminum base-plate with plastic case				
Potting material		Silicone (UL94 V-0)				
Weight		64g (2.26oz)				
MTBF	MIL-HDBK-217F, Full load	5.070 x 10 ⁵ hrs				

Environmental Specifications

Parameter	Conditions	Min	Typ	Max	Unit
Operating base-plate temperature		-40	--	+105	°C
Maximum case temperature		--	--	105	°C
Over temperature protection		--	110	--	°C
Storage temperature range		-55	--	+125	°C
Thermal impedance	Module without assembly option	--	9	--	°C/W
	Only mount on the iron base-plate	--	2.8	--	
	Heat-sink type with 0.24" Height	--	7.1	--	
	Heat-sink type with 0.5" Height	--	5.5	--	
	Heat-sink type with 0.65" Height	--	4.2	--	
	Heat-sink type with 1" Height	--	3.4	--	
Thermal shock					MIL-STD-810F
Vibration					MIL-STD-810F
Relative humidity					5% to 95% RH

EMC Specifications

Parameter	Conditions	Level
EMI	EN55011,EN55032 With external components	Class A, Class B
EMS	EN55024	
ESD	EN61000-4-2 Air \pm 8kV and Contact \pm 6kV	Perf. Criteria A
Radiated immunity	EN61000-4-3 20 V/m	Perf. Criteria A
Fast transient	EN61000-4-4 \pm 2kV	Perf. Criteria A
	43QAE100-24S00W 43QAE100-48S00W	With 2 pcs of aluminum electrolytic capacitor (Nippon chemi-con KY series, 220 μ F/100V)
	43QAE100-110S00W	With 3 pcs of aluminum electrolytic capacitor (Ruby-con BXF series, 100 μ F/250V)
Surge	EN61000-4-5 EN55024: \pm 2kV	Perf. Criteria A
	43QAE100-24S00W 43QAE100-48S00W	With 2 pcs of aluminum electrolytic capacitor (Nippon chemi-con KY series, 220 μ F/100V)
	43QAE100-110S00W	With 3 pcs of aluminum electrolytic capacitor (Ruby-con BXF series, 100 μ F/250V)
Conducted immunity	EN61000-4-6 10 Vr.m.s	Perf. Criteria A
Power frequency magnetic field	EN61000-4-8 100A/m continuous; 1000A/m 1 second	Perf. Criteria A

Note:

1. Input source impedance: The power module will operate as specifications without external components, assuming that the source voltage has a very low impedance and reasonable input voltage regulation. Highly inductive source impedances can affect the stability of the power module. Since real-world voltage source has finite impedance, performance can be improved by adding external filter capacitor.

The 43QAE100-24S00W and 43QAE100-48S00W recommended Nippon Chemi-con KY series, 100 μ F/100V.

The 43QAE100-110S00W recommended Ruby-con BXF series, 39 μ F/200V. 2. BASE-PLATE GROUNDING: When connect two screw bolts to shield plane, the EMI could be reduced.

CAUTION: This power module is not internally fused. An input line fuse must always be used.

Ideal Power Limited

14 Larks Way, Tree Beech Enterprise Park, Gunn, Barnstaple, Devon, England, EX32 7NZ.

www.idealpower.co.uk | +44 (0) 845 260 3400

Page 4 of 10

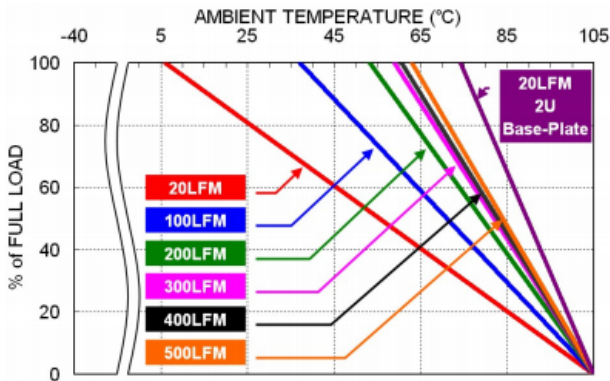
Characteristic Curve

43QAE100-24S05W Derating Curve

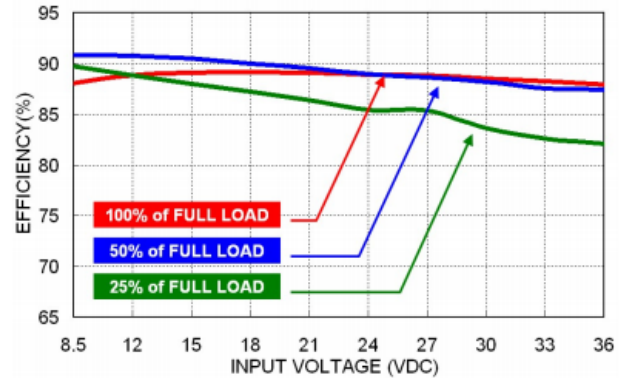

43QAE100-24S05W Efficiency vs. Input Voltage

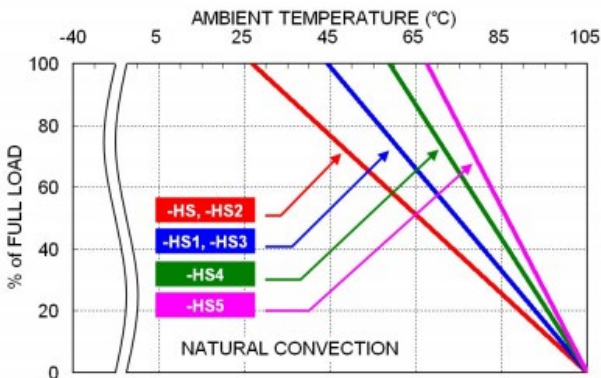
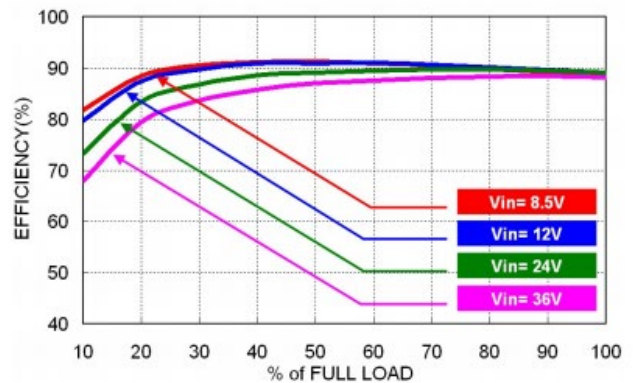
 43QAE100-24S05W Derating Curve with Heat-sink
 (See Thermal Considerations)

43QAE100-24S05W Efficiency vs. Output Load

DC - DC

Fuse Consideration

This power module is not internally fused. An input line fuse must always be used.

This encapsulated power module can be used in a wide variety of applications, ranging from simple stand-alone operation to an integrated part of sophisticated power architecture.

To maximum flexibility, internal fusing is not included; however, to achieve maximum safety and system protection, always use an input line fuse.

The input line fuse suggest as below :

Model	Fuse Rating (A)	Fuse Type
43QAE100-24S□□W	20	Fast-Acting
43QAE100-48S□□W	10	Fast-Acting
43QAE100-110S□□W	4	Slow-Blow

The table based on the information provided in this data sheet on inrush energy and maximum DC input current at low Vin.

Mechanical Drawing

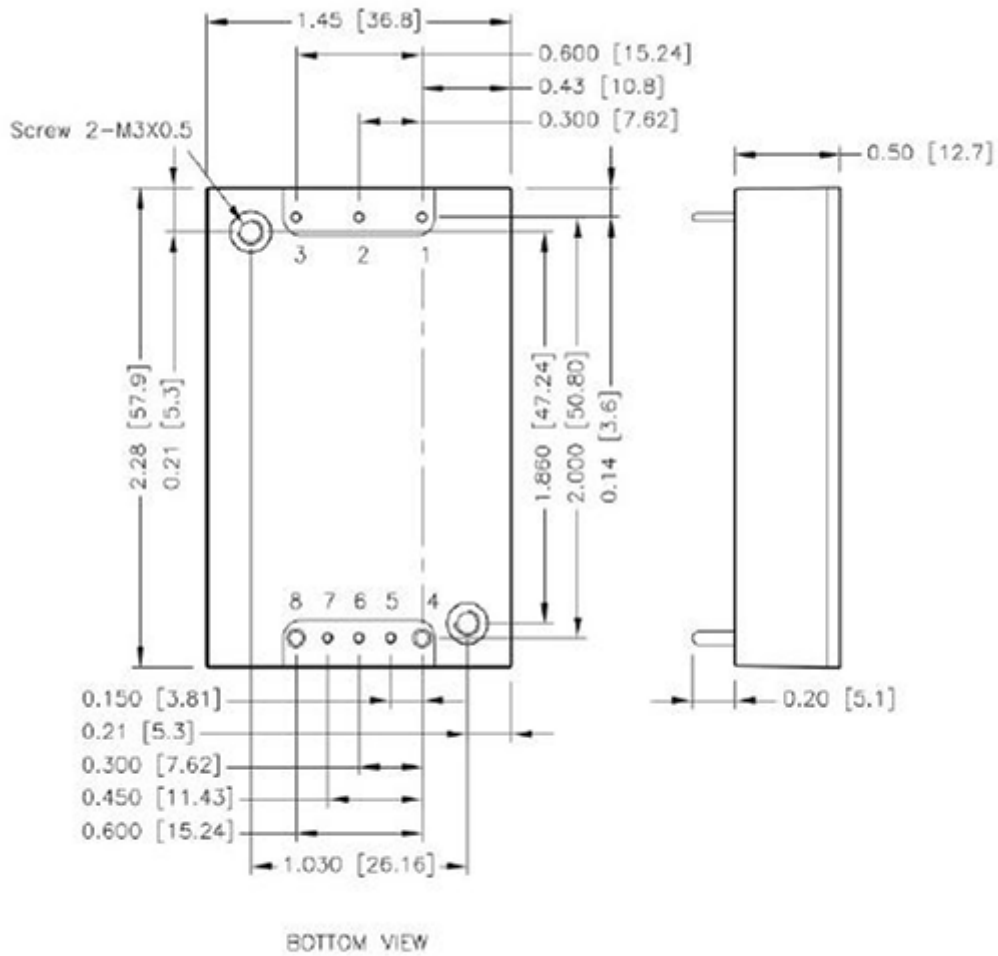

- All dimensions in inch [mm]
Tolerance : x.xx±0.02 [x.x±0.5]
 x.xxx±0.010 [x.xx±0.25]
- Pin pitch tolerance ±0.010 [0.25]
- Pin dimension tolerance ±0.004[0.10]

Pin Connection

Pin	Define	Diameter
1	- Vin	0.04 Inch
2	Ctrl	0.04 Inch
3	+ Vin	0.04 Inch
4	- Vout	0.06 Inch
5	- Sense	0.04 Inch
6	Trim	0.04 Inch
7	+ Sense	0.04 Inch
8	+ Vout	0.06 Inch

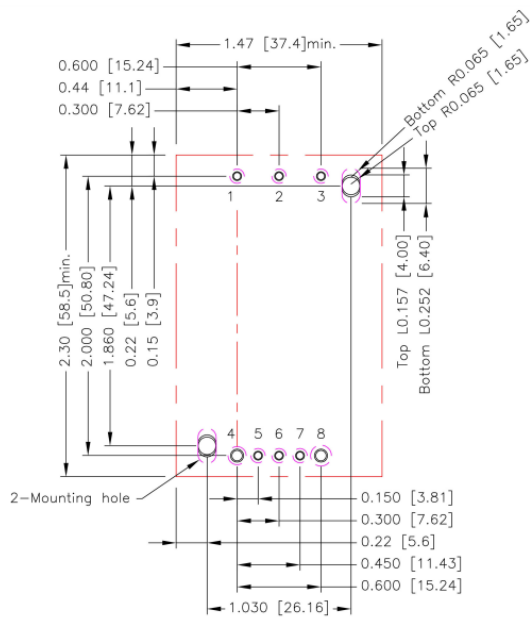
Recommended Pad Layout

All dimensions in inch[mm]
 Pad size(lead free recommended)
 Through hole 1.2.3.5.6.7: $\varnothing 0.051[1.30]$
 Through hole 4.8: $\varnothing 0.075[1.90]$
 Through hole of mounting: $\varnothing 0.126[3.20]$
 Top view pad 1.2.3.5.6.7: $\varnothing 0.064[1.63]$
 Top view pad 4.8: $\varnothing 0.094[2.38]$
 Top view pad of mounting: Groove R0.065[1.65]L0.157[4.00]
 Bottom view pad 1.2.3.5.6.7: $\varnothing 0.102[2.60]$
 Bottom view pad 8: $\varnothing 0.150[3.80]$
 Bottom view pad 4: $\varnothing 0.130[3.30]$
 Bottom view pad of mounting: Groove R0.065[1.65]L0.252[6.40]

Thermal Considerations

The power module operates in a variety of thermal environments. However, sufficient cooling should be provided to help ensure reliable operation of the unit. Heat is removed by conduction, convection, and radiation to the surrounding Environment. Proper cooling can be verified by measuring the point as the figure below. The temperature at this location should not exceed "Maximum case temperature". When operating, adequate cooling must be provided to maintain the test point temperature at or below "Maximum case temperature". You can limit this Temperature to a lower value for extremely high reliability.

- Thermal test condition with vertical direction by natural convection (20LFM).
- The iron base-plate dimension is 19" X 3.5" X 0.063" (The height is EIA standard 2U).
- The heat-sink is optional and P/N: 7G-0029B-F, 7G-0030B-F, 7G-0031B-F, 7G-0032B-F, 7GA0124P01-F, 7GA0125P01-F

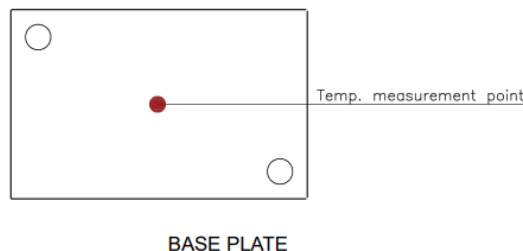

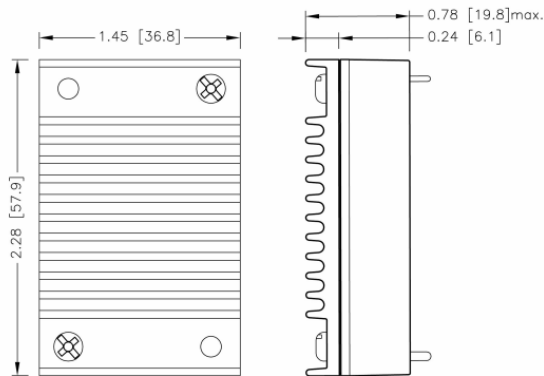
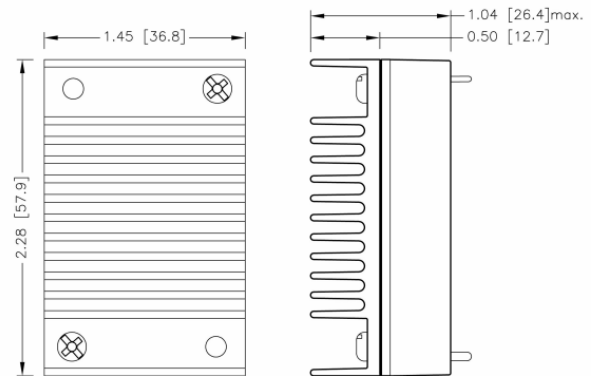
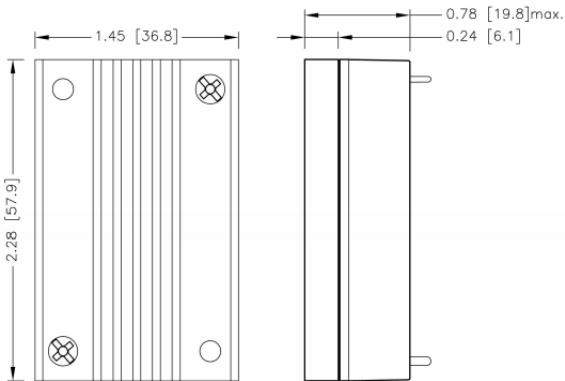
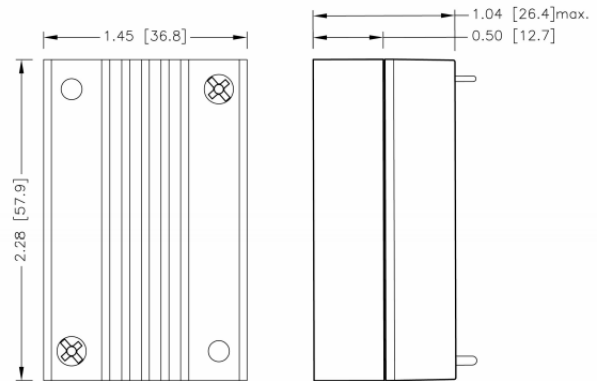
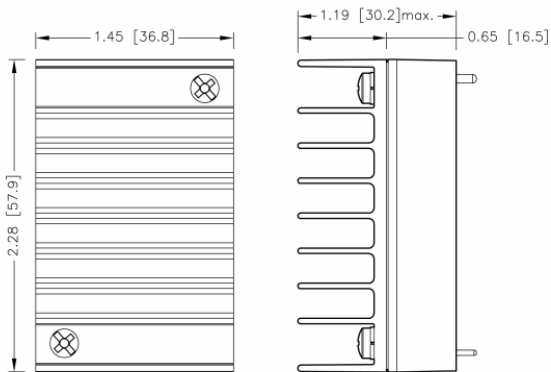
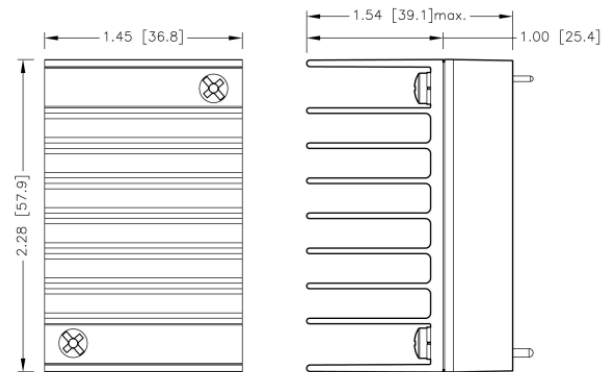
Heat-Sink Type Options
43QAE100-00S00W –HS
7G-0029B-F

43QAE100-00S00W –HS1
7G-0030B-F

43QAE100-00S00W –HS2
7G-0031B-F

43QAE100-00S00W –HS3
7G-0032B-F

43QAE100-00S00W –HS4
7GA0124P01-F

43QAE100-00S00W –HS5
7GA0125P01-F

1. All dimensions in inch [mm]
2. Tolerance :x.xx±0.02 [x.x±0.5]

Output Voltage Adjustment

Output voltage is adjustable for 10% trim up or -20% trim down of nominal output voltage by connecting an external resistor between the Trim pin and either the +Sense or -Sense pins. With an external resistor between the Trim and -Sense pin, the output voltage set point decreases. With an external resistor between the Trim and +Sense pin, the output voltage set point increases. Maximum output deviation is +10% inclusive of remote sense. The external TRIM resistor needs to be at least 1/8W of rated power.

Trim Up Equation

$$R_U = \left(\frac{5.11V_{OUT}(100 + \Delta\%)}{1.225\Delta\%} - \frac{511 + 10.22\Delta\%}{\Delta\%} \right) k\Omega$$

Trim Down Equation

$$R_D = \left(\frac{511}{\Delta\%} - 10.22 \right) k\Omega$$

EXTERNAL OUTPUT TRIMMING

Output can be externally trimmed by using the method shown below.

Trim Up

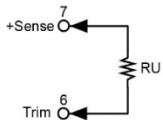

□□S3P3W										
ΔV (%)	1	2	3	4	5	6	7	8	9	10
Vout (V)	3.333	3.366	3.399	3.432	3.465	3.498	3.531	3.564	3.597	3.630
RU (kΩ)	869.117	436.331	292.07	219.939	176.66	147.808	127.198	111.742	99.72	90.103
□□S05W										
ΔV (%)	1	2	3	4	5	6	7	8	9	10
Vout (V)	5.05	5.10	5.15	5.20	5.25	5.30	5.35	5.40	5.45	5.50
RU (kΩ)	1585.35	797.994	535.542	404.316	325.58	273.09	235.596	207.476	185.605	168.109
□□S12W										
ΔV (%)	1	2	3	4	5	6	7	8	9	10
Vout (V)	12.12	12.24	12.36	12.48	12.60	12.72	12.84	12.96	13.08	13.20
RU (kΩ)	4534.55	2287.19	1538.08	1163.52	938.78	788.956	681.939	601.676	539.25	489.309
□□S15W										
ΔV (%)	1	2	3	4	5	6	7	8	9	10
Vout (V)	15.15	15.30	15.45	15.60	15.75	15.90	16.05	16.20	16.35	16.50
RU (kΩ)	5798.49	2925.42	1967.73	1488.89	1201.58	1010.04	873.229	770.619	690.812	626.966
□□S24W										
ΔV (%)	1	2	3	4	5	6	7	8	9	10
Vout (V)	24.24	24.48	24.72	24.96	25.20	25.44	25.68	25.92	26.16	26.40
RU (kΩ)	9590.32	4840.11	3256.7	2465	1989.98	1673.3	1447.1	1277.45	1145.5	1039.94
□□S30W										
ΔV (%)	1	2	3	4	5	6	7	8	9	10
Vout (V)	30.3	30.6	30.9	31.2	31.5	31.8	32.1	32.4	32.7	33
RU (kΩ)	12118.2	6116.57	4116.02	3115.74	2515.58	2115.47	1829.68	1615.33	1448.62	1315.25
□□S48W										
ΔV (%)	1	2	3	4	5	6	7	8	9	10
Vout (V)	48.48	48.96	49.44	49.92	50.40	50.88	51.36	51.84	52.32	52.80
RU (kΩ)	19701.9	9945.94	6693.96	5067.97	4092.38	3441.99	2977.42	2628.99	2357.99	2141.19

Ideal Power Limited

14 Larks Way, Tree Beech Enterprise Park, Gunn, Barnstaple, Devon, England, EX32 7NZ.

www.idealpower.co.uk | +44 (0) 845 260 3400

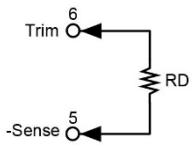
Trim Down

□□S□□W

ΔV (%)	1	2	3	4	5	6	7	8	9	10
RD (k Ω)	500.78	245.28	160.113	117.53	91.98	74.947	62.78	53.655	46.558	40.88
ΔV (%)	11	12	13	14	15	16	17	18	19	20
RD (k Ω)	36.235	32.363	29.088	26.28	23.847	21.718	19.839	18.169	16.675	15.33